

TECHNICAL MANUAL
OPERATOR'S, UNIT AND
DIRECT SUPPORT MAINTENANCE MANUAL
(INCLUDING REPAIR PARTS AND SPECIAL TOOLS LIST)
FOR
KOEHLER ELECTRIC PENSKY-MARTENS
TESTER

NSN 6630-00-530-0987

PRECISION PENSKY-MARTENS FLASH
TESTER

MODEL 74537

NSN 6630-00-244-9415

This technical manual is an authentication of the manufacturer's commercial literature and does not conform with the format and the content requirements normally associated with Army technical manuals. This technical manual does, however, contain all essential information required to operate and maintain the equipment.

Approved for public release; distribution is unlimited.

HEADQUARTERS, DEPARTMENT OF THE ARMY

28 SEPTEMBER 1990

This technical manual is an authentication of the manufacturer's commercial literature and does not conform with the format and the content requirements normally associated with Army technical manuals. This technical manual does, however, contain all essential information required to operate and maintain the equipment.

Approved for public release; distribution is unlimited.

SUPPLEMENTARY INTRODUCTORY MATERIAL

1-1. Maintenance Forms and Records.

Department of the Army forms and procedures used for equipment maintenance will be those described by DA Pam 738-750, The Army Maintenance Management System.

1-2. Reporting Errors and Recommending Improvements.

You can help improve this manual. If you find any mistakes or if you know of a way to improve the procedures, please let us know. Mail your letters, DA Form 2028 (Recommended Changes to Publications and Blank Forms), or DA Form 2028-2 located in the back of this manual, directly to: Commander, U.S. Army Troop Support Command, ATTN: AMSTR-MCTS, 4300 Goodfellow Blvd., St. Louis, MO 63120-1798. A reply will be furnished to you.

1-3. Destruction of Army Material to Prevent Enemy Use.

Refer to TM 750-244-3 for instructions covering the destruction of Army Material to prevent enemy use.

1-4. Administrative Storage of Equipment.

a. Placement of equipment in administrative storage should be for short periods of time when a shortage of maintenance effort exists. Items should be in mission readiness within 24 hours or within the time factors as determined by the directing authority. During the storage period appropriate maintenance records will be kept.

b. Before placing equipment in administrative storage, current preventive maintenance checks and services should be completed. Shortcomings and deficiencies should be corrected, and all modification work orders (MWO's) should be applied.

c. Storage site selection. Inside storage is preferred for items selected for administrative storage. If inside storage is not available, trucks, vans, conex containers and other containers may be used.



K16200 & K16270

ELECTRIC PENSKY-MARTENS TESTER

ASTM D93 & E134

FLASH POINT

BY

PENSKY-MARTENS CLOSED TESTER

KOEHLER
K16200 & K16270
ELECTRIC PENSKY MARTENS TESTER
TABLE OF CONTENTS

SECTION:

- (A) ASSEMBLY PROCEDURE
- (B) INSTRUCTIONS FOR USE & SPARE PARTS
- (C) WIRING DIAGRAM
- (D) MECHANICAL ASSEMBLY DRAWING

K16200 & K16270
ELECTRIC PENSKY MARTENS TESTER

SAFETY AND HAZARD WARNING

THIS EQUIPMENT MAY INVOLVE HAZARDOUS MATERIAL AND OPERATIONS. THIS MANUAL DOES NOT PURPORT TO ADDRESS ALL OF THE SAFETY PROBLEMS ASSOCIATED WITH THE USE OF THE EQUIPMENT. IT IS THE RESPONSIBILITY OF WHOEVER USES THIS EQUIPMENT TO CONSULT AND ESTABLISH APPROPRIATE SAFETY AND HEALTH PRACTICES, AND DETERMINE THE APPLICABILITY OF REGULATORY LIMITATIONS PRIOR TO USE.

NOTE: AS A SAFETY PRECAUTION, NEVER
USE UNREGULATED GAS WITH THIS TESTER

SECTION A

(1) ASSEMBLY PROCEDURE:

NOTE : Unit is partially disassembled to fit into preformed carton for shipping.

TO REASSEMBLE: (See diagram K16200 Electric P.M. Tester)
Components numbered on Diagram K16010, K16020. (-3 -11), (-3 -6) & (-8 -1) have been disassembled for shipping.

(A) Place the mechanical top (K16010) into the cup (K16020) and place on Air Bath.

(B) Install the main gas pipe (-3 -6) into the 1/4 pipe tee using a 3/4 Hex open end or adjustable wrench only, (DO NOT USE PIPE WRENCH) and tighten securely.

(C) Place the cup holder (-3 -11) on the main gas pipe (-3 -6) at a convenient height and tighten thumb screw.

(D) Install the support rod (-8 -1) into the base and tighten set screw in base (-0 -1) to secure rod.

(E) Install the stirrer motor on the support rod (-8 -1).

(F) Connect the flex cable from the mechanical top to the motor and adjust the motor to the angle shown in diagram.

(G) Connect gas inlet to any regulated low pressure (5-10 p.s.i.) gas supply (such as L.P.G. or natural gas). Do not use direct unregulated pressure from an L.P.G. tank.

Unit is now ready for operation. Proceed to instructions page (1).

ELECTRIC PENSKY MARTENS TESTER (K16200)

(ASTM D93 and API 510)

INSTRUCTIONS FOR USE

1. Thoroughly clean and dry all parts of the cup and its accessories before starting the test. Particular care should be taken to avoid the presence of any gasoline or naphtha used to clean the apparatus after a previous test.
2. Fill the cup with the oil to be tested up to the level indicated by the filling mark.
3. Place the lid on the cup and set the latter in the stove. Take care to have the locating devices properly engaged.
4. Insert the thermometer. If it is known that the oil will flash above 220°F., the "P.M. High" thermometer may be selected; otherwise it is preferable to start with the "P.M. Low" thermometer, and then change in case a temperature of 220 to 230°F. is reached.
5. Light the test flame and adjust by means of the valve screw on the burner block, so that it is 5/32" diameter, the same size as the bead provided for comparison.
6. Connect the instrument to the proper source of electric current, with the electrical cord provided.
7. Adjust the supply of heat by adjusting the dial on the powerstat until the temperature reading on the thermometer increases by not less than 9°, nor more than 11°F., per minute.
8. Connect the stirrer to the stirrer motor. NOTE: Use receptacle in base of powerstat heater and place switch to ON.
9. Apply the test flame at each temperature reading, which is a multiple of 2°F., up to 220°F. For the temperature range above 220°F., apply the test flame at each temperature reading which is a multiple of 5°F. Apply the test flame by operating the knurled hand knob controlling the shutter and test flame burner, so that the flame is lowered in one-half second, left in its lowered position for one second, and quickly raised to its high position. Discontinue stirring during the application of the test flame.
10. Record as the flash point the temperature read on the thermometer at the time of the flame application that causes a distinct flash in the interior of the cup. The true flash must not be confused with the bluish halo that sometimes surrounds the test flame for the applications preceding the one that causes the actual flash.

ELECTRIC PENSKY MARTENS TESTER

INSTRUCTIONS FOR USE

(2 of 2)

Samples of asphalts or very viscous materials may be warmed until they are reasonably fluid before they are tested. However, no sample should be heated more than is absolutely necessary. It shall never be heated above a temperature of 30°F. below its excepted flash point.

For the determination of flash point of suspensions of solids, bring the material to be tested and the tester to a temperature of 60° +/- 10°F., or 20°F. lower than the estimated flash point, whichever is lower. Turn the stirrer 250 +/- 10 RPM, stirring in a downward direction. Raise the temperature throughout the duration of the test at a rate of not less than 2° nor more than 3° F. With the exception of these requirements for rates of stirring and heating, proceed as prescribed above.

For further details consult ASTM D93.

PARTS LIST

K16010	TOP
K16020	CUP
K160-3-3	Brass Bell (K160-3-3)
K160-3-2	Cast Iron Bell (K160-3-2)
K4160-1-14	Thermometer Ferrule Adapter
K145-8	Thermometer Ferrule (Includes K145-8-3 Alum. Ring)
K160-9	Flexible Shaft & Coupling
K160-3-4	Upright Rod (K160-3-4)
K162-2MO	Motor, Stirrer
	Powerstat (280-115-001-115V) (280-230-001-230V)
	Heater, 750W. (225-115-001-115V) or (225-230-001-230V)
K420-0-2	Heater Shell (K420-0-2)
K162-0-1	Base (K162-0-1)

KOEHLER INSTRUMENT COMPANY, INC.

Bohemia, L.I. New York

K 420 FOR USE WITH K162, K194A, K100-2
 &
K420A

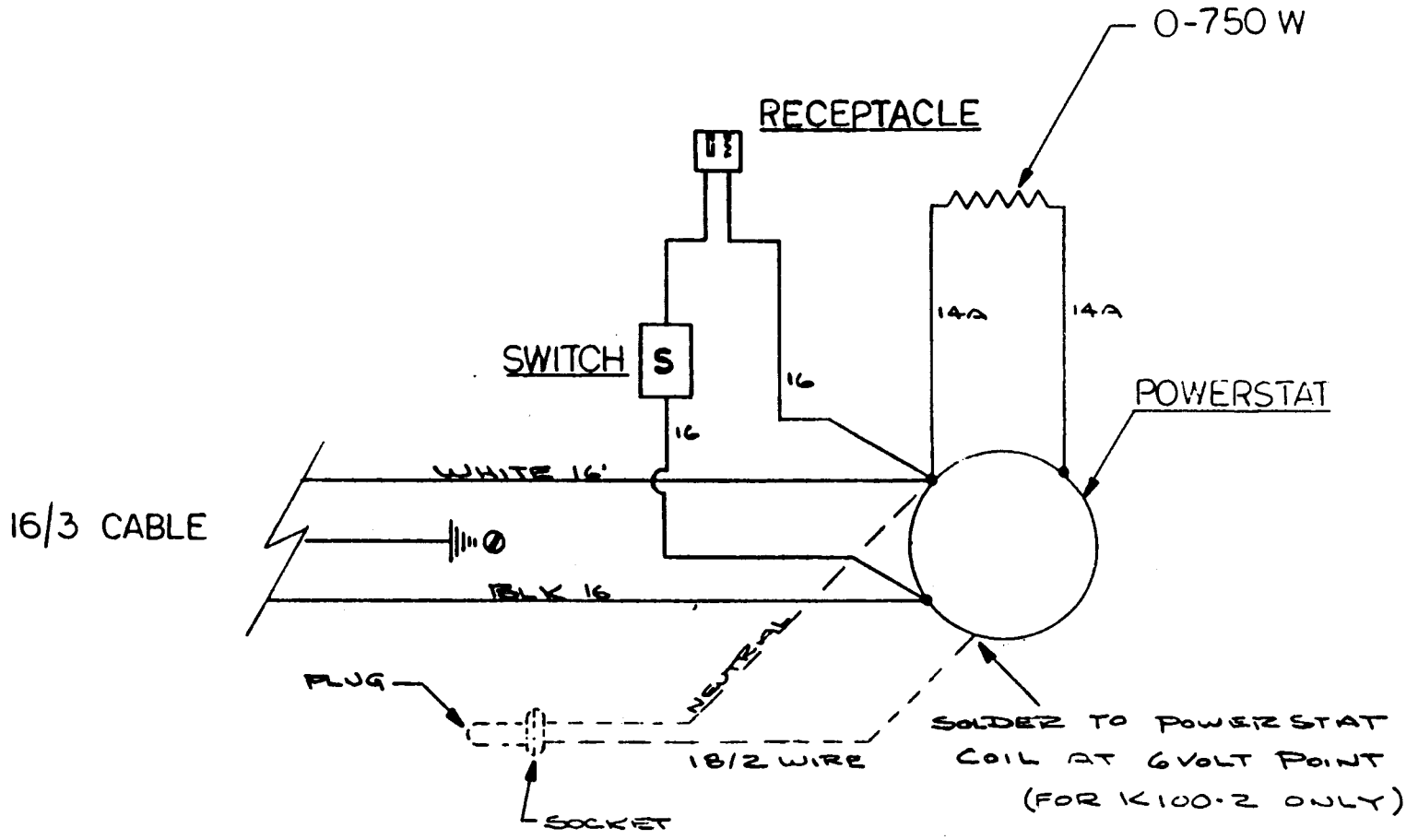

INSTRUMENT: SEE ABOVE		NO. RECD.	TITLE: POWERTROL HEATER	KOEHLER INSTRUMENT CO. INC. 1595 SYCAMORE AVENUE BOHEMIA, N.Y.	
MAT'L	FINISH			SCALE	SHEET

FOR USE WITH K420A K162C K100-2A K194A-1

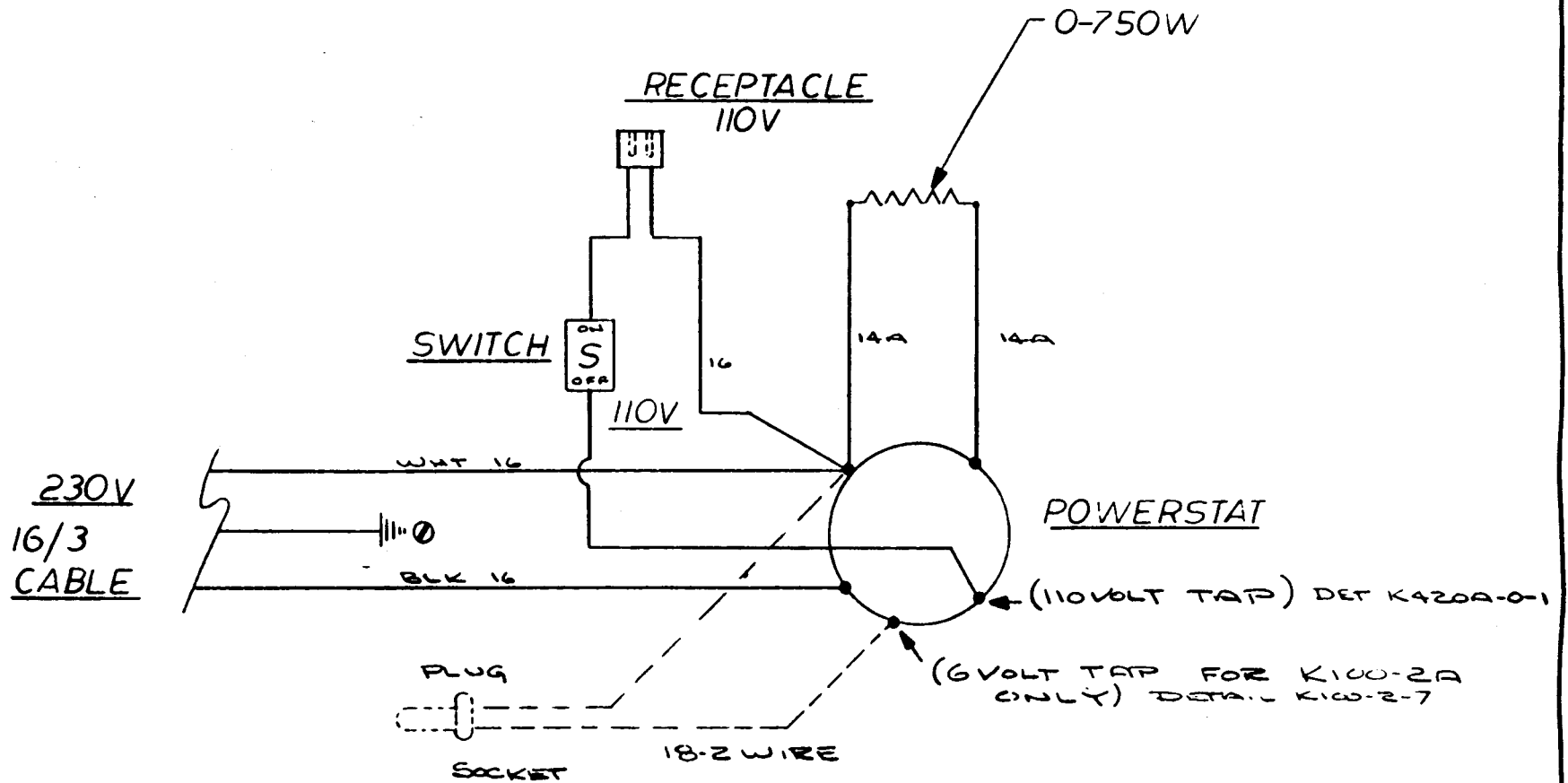

INSTRUMENT: SEE TABLE		NO. REQD.	TITLE: 230VOLT POWERTROL HTR.		KOEHLER INSTRUMENT CO. INC. 1595 SYCAMORE AVENUE BOHEMIA N Y	
MAT'L	FINISH	SCALE	SHEET 1 OF 1	PART NO WIRING DIAGRAM		

7-26-85

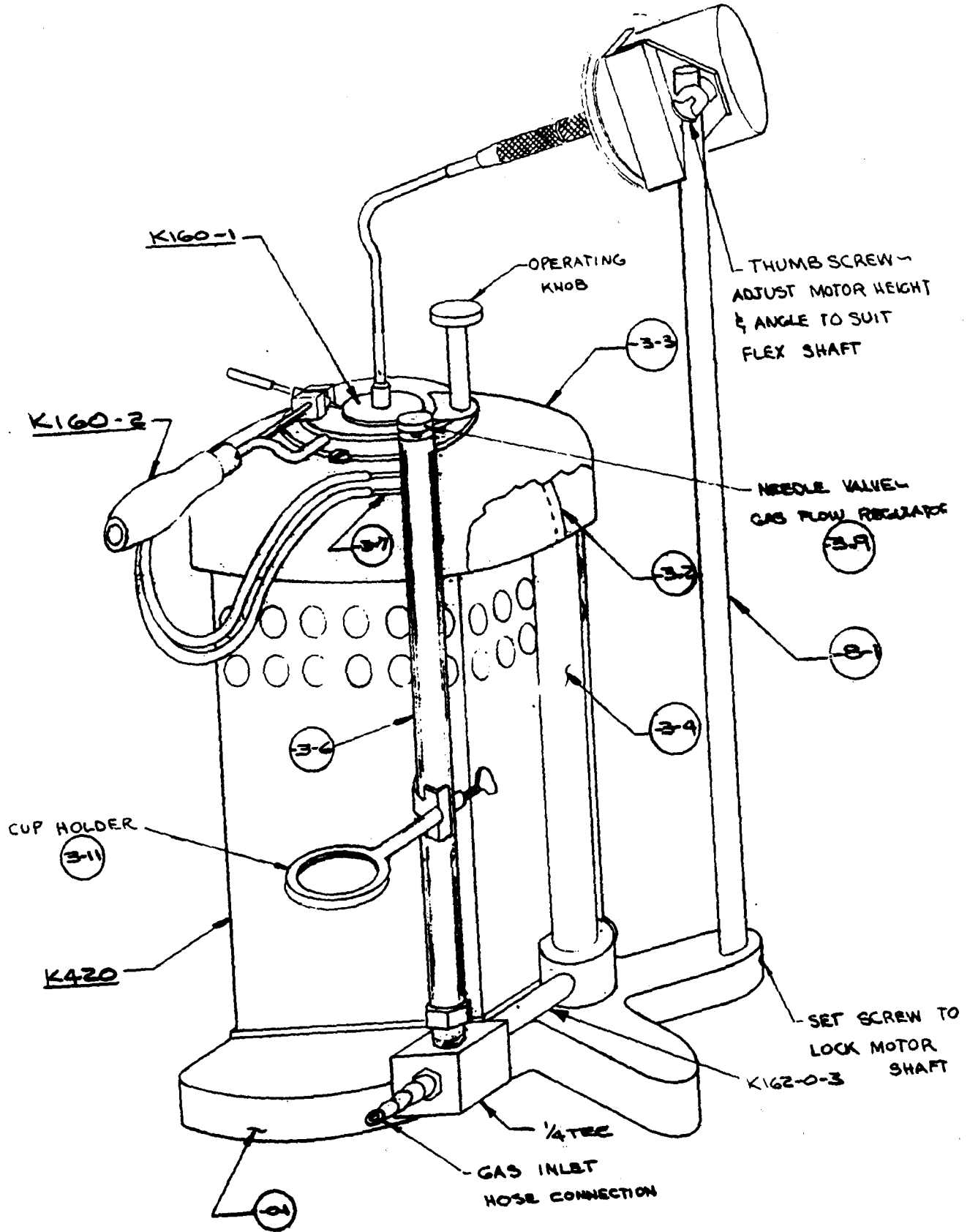



WARRANTY POLICY

Any product* manufactured by Koehler Instrument Co. , Inc. (hereinafter referred to as the company) is sold on the following basis and none other. ALL IMPLIED WARRANTIES OF MERCHANTABILITY AND OF FITNESS FOR A PARTICULAR PURPOSE ARE HEREBY EXPRESSLY EXCLUDED.

The following warranty shall apply, and no other warranty, express or implied, shall apply.

If within one year from date of shipment the product fails because of defective material or poor workmanship, the company will repair or replace, without charge, any product that has failed provided:

- a) the product has been properly installed, operated and maintained.
- b) the company is advised in writing of the malfunction and authorizes the return of the product to the factory.
- c) All transportation charges for the return to the factory are prepaid. (Products will be returned freight collect.)
- d) A complete description of the reason for return must accompany the unit.

NOTE: A nominal handling charge for inspection will be made on units for which a claimed defect cannot be confirmed.

THE COMPANY'S SOLE LIABILITY HEREUNDER SHALL BE TO REPAIR OR REPLACE ANY PRODUCT WHICH HAS NOT COMPLIED WITH THIS WARRANTY.

In no event shall the company be liable for:

- 1) Prospective profits or special, indirect or consequential damages caused by failure of its product.
- 2) Any charges for labor or materials for work done on its products by others.

*Wherever used in this Warranty Policy the term "product" shall mean any items manufactured and/or sold by Koehler Instrument Co., Inc.

Precision[®]

Instruction Manual TS-74537 AP-9

Pensky-Martens Flash Testers

Catalog 74537, 74540

Catalog 74545

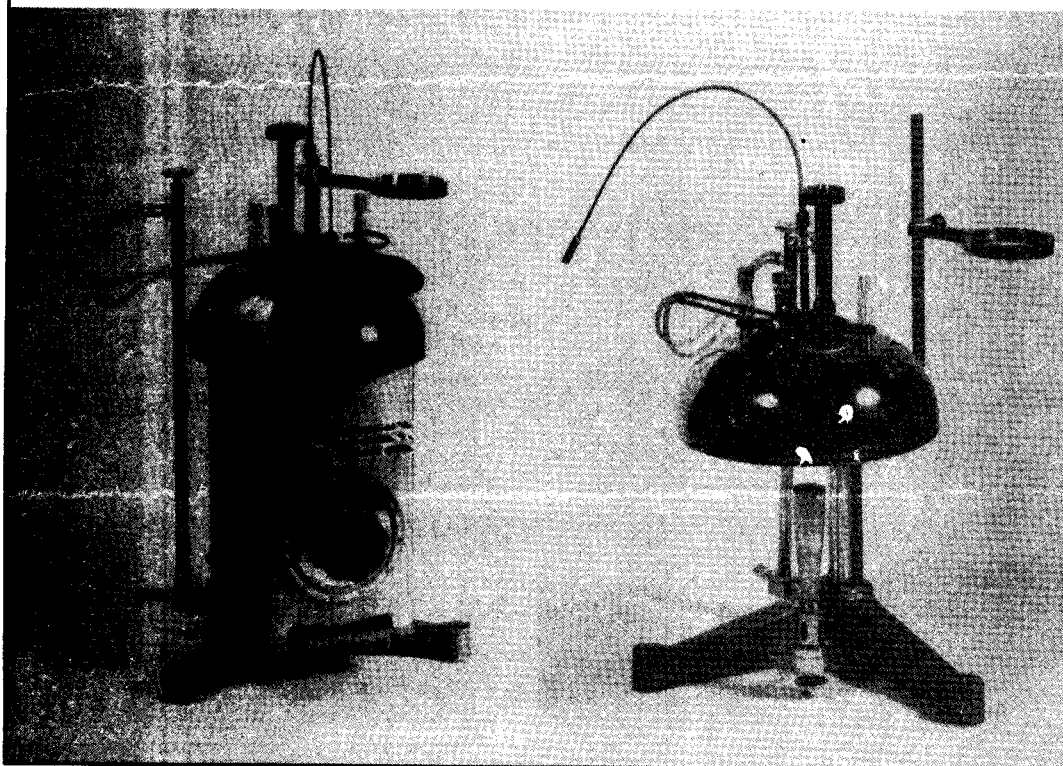

Precision Scientific

Precision Scientific Inc. 3737 W. Cortland St. • Chicago, IL 60647 • 312-227-2660 Telex: 4330120 (ITT), 254028 (WU) • Fax: 312-227-1828

Pensky-Martens Flash Testers Catalog 74537, 74540 and 74545

Introduction

Your satisfaction and safety are important to PRECISION SCIENTIFIC and a complete understanding of this unit is necessary to attain these objectives.

As the ultimate user of this apparatus, it is your responsibility to understand its proper function and operational characteristics. This instruction manual should be thoroughly read and all operators given adequate training before attempting to place this unit in service. Awareness of the stated cautions and warnings, and compliance with recommended operating parameters--together with maintenance requirements--are important for safe and satisfactory operation. The unit should be used for its intended application; alterations or modifications will void the Warranty.

WARNING: As a routine laboratory precaution, always wear safety glasses when working with this apparatus.

This product is not intended, nor can it be used, as a sterile or patient connected device. In addition, this apparatus is not designed for use in Class I, II, or III locations as defined by the National Electrical Code.

Unpacking and damage

Save all packing material if apparatus is received damaged. This merchandise was carefully packed and thoroughly inspected before leaving our factory.

Responsibility for its safe delivery was assumed by the carrier upon acceptance of the shipment; therefore, claims for loss or damage sustained in transit must be made upon the carrier by the recipient as follows:

Visible Loss or Damage: Note any external evidence of loss or damage on the freight bill, or express receipt, and have it signed by the carrier's agent. Failure to adequately describe such external evidence of loss or damage may result in the carrier's refusing to honor your damage claim. The form required to file such a claim will be supplied by the carrier.

Concealed Loss or Damage: Concealed loss or damage means loss or damage which does not become apparent until the merchandise has been unpacked and inspected. Should either occur, make a written request for inspection by the carrier's agent within 15 days of the delivery date; then file a claim with the carrier since the damage is the carrier's responsibility.

By following these instructions carefully, we guarantee our full support of your claim to be compensated for loss from concealed damage.

DO NOT -- FOR ANY REASON -- RETURN THIS UNIT WITHOUT FIRST OBTAINING AUTHORIZATION. In any correspondence to PRECISION SCIENTIFIC please supply the nameplate data, including catalog number and serial number.

General information

These instructions encompass the models listed below with their specific electrical characteristics:

Cat.	No.	volts	Hertz	Amps	Watts
	74537	120	50/60	6.3	750
	74540	220	50/60	3.4	750
	74545	Gas Heat, all commercial gases			

The Pensky-Martens Flash Point Tester conforms to ASTM D-93 and is designed to determine the flash point of fuel oils, lube oils, suspensions of solids, liquids that tend to form a surface film under test conditions, and other liquids.

Installation and Operation

ASTM D-93 outlines the installation and operational procedures required for the determination of flash points and should be referred to in all cases.

ASTM methods can be obtained from:

American Society for Testing Materials
1916 Race Street
Philadelphia, Pennsylvania 19103

SAFETY CONSIDERATIONS AND WARNINGS:

The following guidelines are presented to supplement the existing safety rules enforced by your company:

1) Safety glasses should be worn by the operator and by anyone in the vicinity who could be splashed by liquid samples.

2) It is recommended that a fire extinguisher of Halon 1211 or CO₂ (at least a 5-lb. tank size) be placed conveniently in reach of the operator to protect against fires caused by the sample which might accidentally ignite during test.

3) Service or circuit testing should be attempted only by a qualified person who has been trained with regard to the potential danger of working with live electrical circuitry.

WARNING : Disconnect the unit from the power source whenever replacing electrical components.

Electrical Connections: Important
(Please Read Carefully.)

The services of a qualified technician should be used to install this unit. It should be determined that the power supply receptacle is properly polarized and grounded.

As delivered, it is supplied with a standard three-wire polarized line cord and plug for operation on 120 volts, single phase, 50/60 Hertz, or 220V, 50/60 Hertz.

WARNING: For personal safety, this unit must be properly grounded.

When a two-prong wall receptacle is encountered, it is the personal responsibility and obligation of the installer to have it replaced with a properly grounded three-prong receptacle.

WARNING: DO NOT, under any circumstances, cut or remove the third (ground) prong from the power cord. DO NOT use a two-prong adapter plug.

Determine the total amount of current presently being used by other apparatus to the circuit that will be used for this apparatus.

INSTALLATION (Contd.)

Electrical Connections: (Contd.)

It is critical that the added current demand and other equipment on the circuit not exceed the rating of the fuse or circuit breaker, in use, on this circuit.

CAUTION: Be sure that the power supply is of the same voltage as specified on the nameplate.

Explanation of controls

Electric Heat:

The Pensky-Martens Flashpoint Tester stepless transformer for variable heat control (from 0 to 750 watts). The reference heater dial is conveniently worked from 0 to 100. The numbers are strictly for reference to the heater wattage. To

increase the heat, turn dial counter-clockwise; to decrease heat, turn dial clockwise.

Gas Heat:

Adjusting the gas heat should be done by rotating the needle valve at the base of the unit. The heat source should be centered under the opening of the heating plate.

CAUTION: Under no circumstances should products of combustion or free flame be allowed to come up around the cup .

Thermometers:

Thermometers are not supplied with the Flash Tester. When working in the 50 to 230°F (10 to 110°C) range, it is recommended that an ASTM Thermometer 9F (20 to 230°F) or 9C (-7 to 110°C) be used. When working in the 200 to 700°F (90 to 370°C) range, it is recommended that an ASTM Thermometer 16F, (200° to 700°F) or 16C (90 to 370°C) be used.

Parts List

<u>Description</u>		<u>Qty</u>	74537	74540	74545
1	Knob, Ceramic	2	510624		
2	Flash Cup	1	74548		
3	Burner	1	N/A	510056	
4	Valve, Needle	1	N/A	509744	
5	Orifice	1	N/A	509784	
6	Cover with Operating Mechanism	1	74549		
7	Tubing, Pure Gum Rubber	2 ft.	166340		
8	Screw, Orifice Pivot	1	510037		
9	Propeller, Upper (small)*	1	510032		
10	Propeller, Lower (large)*	1	510033		
11	Shaft, Stirrer*	1	510030		
12	Orifice	1	510025		
13	Valve, Orifice	1	509738		
14	Ferrule, Thermometer	1	517407		
15	Spring*	1	510017		
16	Pulley	1	524923		
17	Flexible Shaft, Hand Stirrer	1	74553		
18	Spacer	2	520699		
19	Dome	1	515975		
20	Support Rod, Motor	1	507083		
21	Tube, Gas Line	1	515969		520548
22	Valve, Needle (gas line tube)	1	515966		
23	Flash Cup Holder	1	515965		
24	Thumbscrew, Flash Cup Holder	1	428915		
25	Heater, Full Control	1	536942	540094	N/A
26	Lower Refractory with Heater*	1	61856	540095	N/A
27	Heater, element only*	1	61876	61877	N/A
28	Transformer (Ohmite)*	1	225086	N/A	N/A
	Brush*	1	225087	N/A	N/A
29	Transformer (Staco)*	1	225086	225239	N/A
	Brush*	1	225234	225261	N/A

* Not shown.

Accessories

Slow Speed Stirrer, 115V, 60 Hz.
 Slow Speed Stirrer, 220V, 50 Hz.

75765
 75766

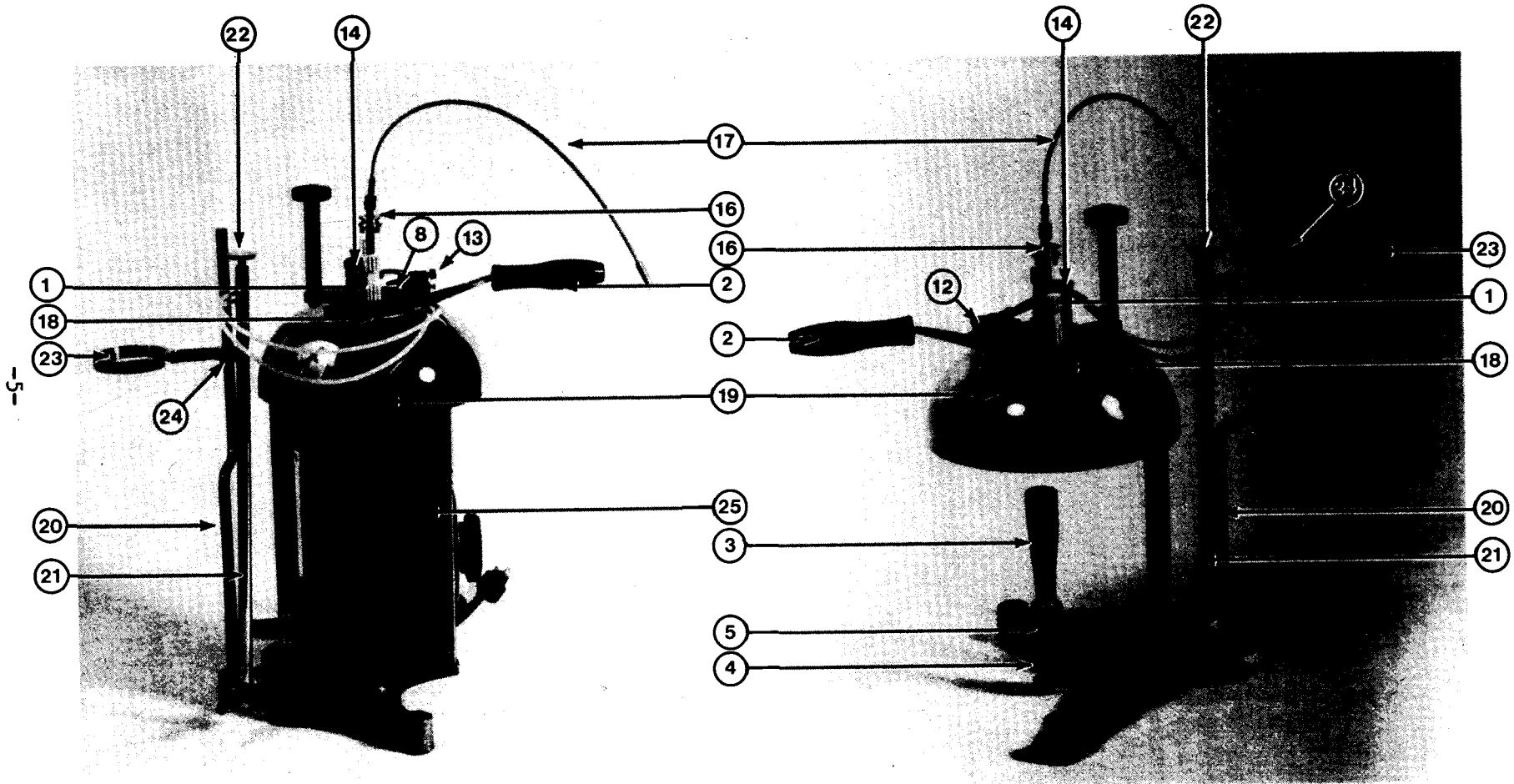

74537 & 74540

74545

Exclusive Precision® Warranty

PRECISION SCIENTIFIC warrants its products against defects in material or in workmanship, when used under appropriate conditions and in accordance with appropriate operating instructions for a period of no less than one (1) year from the date of delivery of the products.

Sole obligation of PRECISION SCIENTIFIC shall be to repair or replace at our option, FOB factory or locally, without charge, any part(s) that prove defective within the warranty period, provided the customer notifies PRECISION SCIENTIFIC promptly and in writing of any such defect. Compensation for labor by other than PRECISION SCIENTIFIC employees will not be our obligation. Part(s) replacement does not constitute an extension of the original warranty period.

PRECISION SCIENTIFIC MAKES NO WARRANTY OF MERCHANTABILITY, FITNESS FOR A PARTICULAR PURPOSE, OR ANY OTHER WARRANTY, EXPRESSED OR IMPLIED, AS TO THE DESIGN, SALE, INSTALLATION, OR USE OF ITS PRODUCTS, AND SHALL NOT BE LIABLE FOR CONSEQUENTIAL DAMAGES RESULTING FROM THE USE OF ITS PRODUCTS.

PRECISION SCIENTIFIC will not assume responsibility for unauthorized repairs or failure as a result of unauthorized product modifications, or for repairs, replacements, or modifications negligently or otherwise improperly made or performed by persons other than PRECISION SCIENTIFIC employees or authorized representatives.

While our personnel are available to advise customers concerning general applications of all manufactured products, oral representations are not warranties with respect to particular applications and should not be relied upon if inconsistent with product specifications or the terms stated herein.

In any event, the terms and conditions contained in PRECISION SCIENTIFIC formal sales contracts shall be controlling; and any changes must be in writing and signed by an authorized executive of PRECISION SCIENTIFIC.

All defective components will be replaced without charge one (1) year from the date of delivery. There will be no charge for labor if the apparatus is returned to the factory prepaid.

Conditions and qualifications of the warranty statement shall prevail at all times.

APPENDIX A
REFERENCES

A-1 . **Scope.** This appendix contains all forms, pamphlets and technical manuals referenced in both the Air mobile and Semitrailer mounted Laboratories.

A-2. Forms.

Recommended Changes to Publications	DA Form 2028
	DA Form 2028-2
Quality Deficiency Report	SF 368
Equipment Inspection and Maintenance Work Sheet	DA Form 2404
Hand Receipts	DA Form 2062

A-3. Field Manuals.

Petroleum Testing Facilities:

Laboratories and Kits	FM10-72
inspecting and Testing Petroleum Products	FM10-70
ASTM Test Method Supplement to	FM10-92C1/C2

A-4. Technical Manuals.

Atlas-Copco Compressor	TM 10-4310-392-13&P
Alcor Jet Fuel Thermal Oxidation Tester Operating and Maintenance Manual	TM 10--6635-210-13&P
Bacharach Gas Alarm and Calibration Data	TM 10--6665-297-13&P
Brother Portable Typewriter	TM 10-7430-218-13&P
Chemtrix Field Ph Meter	TM 10-6630-237-13&P
Elkay Manufacturing 30 GPH Cooler	TM 10-4130-240-13&P
Emcee Micro-Separometer	TM 10-6640-222-13&P
Foxboro Pressure Recording Gauge	TM 10-6685-365-13&P
Gammon Aqua Glo Water Detector	TM 10-6640-221-13&P
Gammon Mini Monitor Fuel Sampling Kit	TM 10-6630-230-13&P
Jelrus Burn-Out Furnace	TM 10-6640-231-13&P
Koehler Cleveland Open Tester	TM 10-6630-236-13&P
Koehler Cloud and Pour Point Chamber..	TM 10-6630-238-13&P
Koehler Copper Strip Corrosion Bomb Bath	TM 10-6640-220-13&P
Koehler Distillation Apparatus	TM 10-6630-233-13&P
Koehler Dropping Point Apparatus	TM 10-6635-211-13&P
Koehler Electric Pensky-Martins Tester	TM 10-6630-231-13&P
Koehler Foaming Characteristics Determination Apparatus	TM 10-6640-228-13&P
Koehler Kinematic Viscosity Bath	TM 10-6630-239-13&P
Koehler Tag Closed Cup Flash Tester	TM 10-6630-235-13&P
Lab-Line Explosion Proof Refrigerator	TM 10-6640-219-13&P
Lily Freezer	TM 10-6640-234-13&P
Millipore 0M 39 Filter Holder	TM 10-6640-225-13&P
Millipore Vacuum Pump	TM 10-6640-217-13&P
Ohaus Harvard Trip Balance	TM 10-6670-278-13&P
Precision Gas-Oil Distillation Test Equipment	TM 10-6630-219-13&P
Precision General Purpose Water Bath	TM 10-640-229-13&P

TM 10-6630-231-13&P

Precision High Temperature Bronze Block Gum Bath	TM 10-6630-234-13&P
Precision General Purpose Ovens	TM 10-6640-218-13&P
Precision Heater Instruction Manual and Parts List	TM 10-6640-223-13&P
Precision Oxidation Stability Bath	TM 10-6640-232-13&P
Precision Pensky-Martens Flash Testers	TM 10-6630-231-13&P
Precision Reid Vapor Pressure Bath	TM 10-6640-226-13&P
Precision W-Speed Stirrer	TM 10-6640-224-13&P
Precision Universal Centrifuge	TM 10-6640-230-13&P
Precision Universal Penetrometer	TM 10-6640-228-13&P
Sargent-Welch Vacuum Pump	TM 10-4310-391-13&P
Sartorius Analytical Balance	TM 10-6670-277-13&P
Scotsman Cuber	TM 10-6640-227-13&P
Soltec VOM-Multimeter	TM 10-6625-3127-13&P
Teel Self-Priming Centrifugal Pump	TM 10-6640-217-13&P
Teel Submersible Pump	TM 10-4320-320-13&P
Texas Instrument TI-5030II Calculator	TM 10-7420-210-13&P

A-5. Pamphlets.

The Army Maintenance Management System (TAMMS)	DA Pam 738-750
--	----------------

A-6. Miscellaneous Publications.

The Army integrated Publishing and Printing Program	AR 25-30
Laboratory, Airmobile, Aviation Fuel	MIL-L-52733A(ME)
Apparatus, Instruments, Chemicals, Furniture, and Supplies for industrial, Clinical, College and Government Laboratories	Fisher Scientific Laboratories Catalog
Petroleum-Petrochemical Testing Equipment	Precision Scientific Catalog

APPENDIX B

MAINTENANCE ALLOCATION CHART

Section I. INTRODUCTION

B-1. General.

a. This section provides a general explanation of all maintenance and repair functions authorized at various maintenance categories.

b. The Maintenance Allocation Chart (MAC) in Section II designates overall authority and responsibility for the performance of maintenance functions on the identified end item or component. The application of the maintenance functions to the end item or component will be consistent with the capacities and capabilities of the designated maintenance categories.

c. Section III lists the tools and test equipment (both special tools and common tool sets) required for each maintenance function as referenced from Section II.

d. Section IV contains supplemental instructions and explanatory notes for a particular maintenance function.

B-2. **Maintenance Functions.** Maintenance functions will be limited to and defined as follows:

a. Inspect. To determine the serviceability of an item by comparing its physical, mechanical, and/or electrical characteristics with established standards through examination (e.g., by sight, sound, or feel).

b. Test. To verify serviceability by measuring the mechanical, pneumatic, hydraulic, or electrical characteristics of an item and comparing those characteristics with prescribed standards.

c. Service. Operations required periodically to keep an item in proper operating condition, i.e., to clean (includes decontaminate, when required), to preserve, to drain, to paint, or to replenish fuel, lubricants, chemical fluids, or gases.

d. Adjust. To maintain or regulate, within prescribed limits, by bringing into proper or exact position, or by setting the operating characteristics to specified parameters.

e. Align. To adjust specified variable elements of an item to bring about optimum or desired performance.

f. Calibrate. To determine and cause corrections to be made or to be adjusted on instruments or test, measuring, and diagnostic equipments used in precision measurement. Consists of comparisons of two instruments, one of which is a certified standard of knob accuracy, to detect and adjust any discrepancy in the accuracy of the instrument being compared.

g. Remove/Install. To remove and install the same item when required to perform service or other maintenance functions. Install may be the act of emplacing, seating, or fixing into position a spare, repair part, or module (component or assembly) in a manner to allow the proper functioning of an equipment or system.

h. Replace. To remove an unserviceable item and install a serviceable counterpart in its place. "Replace" is authorized by the MAC and is shown as the third position code of the SMR code.

i. Repair. The application of maintenance services, ¹including fault location/troubleshooting,² removal/installation, and disassembly/assembly procedures,³ and maintenance actions⁴ to identify troubles and restore serviceability to an item by correcting specific damage, fault, malfunction, or failure in a part, subassembly, module (component or assembly), end item, or system.

j. Overhaul. That maintenance effort (service/action) prescribed to restore an item to a completely serviceable/operational condition as required by maintenance standards in appropriate technical publications (i.e., DMWR). Overhaul is normally the highest degree of maintenance performed by the Army. Overhaul does not normally return an item to like-new condition.

k. Rebuild. Consists of those services/actions necessary for the restoration of unserviceable equipment to a like-new condition in accordance with original manufacturing standards. Rebuild is the highest degree of materiel maintenance applied to Army equipment. The rebuild operation includes the act of returning to zero those age measurements (hours/miles, etc.) considered in classifying Army equipment/components.

B-3. Explanation Of Columns In The MAC, Section II.

a. Column 1. Group Number. Column 1 lists functional group code numbers, the purpose of which is to identify maintenance significant components, assemblies, subassemblies, and modules with the next higher assembly. End item group number shall be "00."

b. Column 2. Component/Assembly. Column 2 contains the names of components, assemblies, subassemblies, and modules for which maintenance is authorized.

c. Column 3. Maintenance Function. Column 3 lists the functions to be performed on the item listed in column 2. (For a detailed explanation of these functions, see paragraph B-2.)

d. Column 4. Maintenance Category. Column 4 specifies, by the listing of a work time figure in the appropriate subcolumn(s), the category of maintenance authorized to perform the function listed in column 3. This figure represents the active time required to perform that maintenance function at the indicated category of maintenance. If the number or complexity of the tasks within the listed maintenance function vary at different maintenance categories, appropriate work time figures will be shown for each category. The work time figure represents the average time required to restore an item (assembly, subassembly, component, module, end item, or system) to a serviceable condition under typical field operating conditions. This time includes preparation time (including any necessary disassembly/assembly time), troubleshooting/fault location time, and quality assurance/quality control time in addition to the time required to perform the specific tasks identified for the maintenance functions authorized in the maintenance allocation chart. The symbol designations for the various maintenance categories are as follows:

¹ Services - inspect, test, service, adjust, align, calibrate, and/or replace.

² Fault locate/troubleshoot -the process of investigating and detecting the cause of equipment malfunctioning; the act of isolating a fault within a system or unit under test (UUT).

³ Disassemble/assemble- encompasses the step-by-step taking apart (or breakdown) of a spare/functional group coded item to the level of its least componency identified as maintenance significant (i. e., assigned an SMR code) for the category of maintenance under consideration.

⁴ Actions - welding, grinding, riveting, straightening, facing, remachining, and/or resurfacing.

- C Operator/Crew
- O Unit Maintenance
- F Direct Support Maintenance
- H General Support Maintenance
- D Depot Maintenance

e. **Column 5. Tools and Equipment.** Column 5 specifies, by code, those common tool sets (not individual tools) and special tools, TM DE, and support equipment required to perform the designated function.

f. **Column 6. Remarks.** This column shall, when applicable, contain a letter code, in alphabetic order, which shall be keyed to the remarks contained in section IV.

B-4. Explanation Of Columns In Tool And Test Equipment Requirements, Section III.

a. **Column 1. Reference Code.** The tool and test equipment reference code correlates with a code used in the MAC, section II, column 5.

b. **Column 2. Maintenance Category.** The lowest category of maintenance authorized to use the tool or test equipment.

c. **Column 3. Nomenclature.** Name or identification of the tool or test equipment.

d. **Column 4. National Stock Number.** The National stock number of the tool or test equipment.

e. **Column 5. Tool Number.** The manufacturer's part number.

B-5. Explanation Of Columns In Remarks, Section IV.

a. **Column 1. Reference Code.** The code recorded in column 6, Section II.

b. **Column 2. Remarks.** This column lists information pertinent to the maintenance function being performed as indicated in the MAC, section II.

Section II. MAINTENANCE ALLOCATION CHART

(1) GROUP NUMBER	(2) COMPONENT/ ASSEMBLY	(3) MAINTENANCE FUNCTION	(4) MAINTENANCE LEVEL					(5) TOOLS AND EQUIPMENT	(6) REMARKS
			UNIT	DS	GS	DEPOT			
			C	O	F	H	D		
	TESTER, FLASH POINT (CLOSED)	INSPECT REPLACE REPAIR	0.3	0.3 1.5	1.0			1, 2	A

SECTION III. TOOL AND TEST EQUIPMENT REQUIREMENTS
FOR
MAINTENANCE ALLOCATION CHART

(1) TOOL/TEST EQUIP. REF CODE	(2) MAINTENANCE CATEGORY	(3) NOMENCLATURE	(4) NSN	(5) TOOL NUMBER
1	O	TOOL KIT, GENERAL AUTOMOTIVE	5180-00-177-7033	(50980) SC 5180-90- CL-N26
2	O	MULTIMETER, 0-500V	6625-00-691-2453	

SECTION IV. REMARKS

REFERENCE

CODE	REMARKS
A	REPLACE DEFECTIVE PARTS

APPENDIX C

COMPONENTS OF END ITEM AND BASIC ISSUE ITEMS LISTS

Section I. INTRODUCTION

C-1. Scope.

This appendix lists components of end item and basic issue items for the Electric Pensky-Martens Tester to help you inventory items required for safe and efficient operation.

C-2. General.

The Components of End Item and Basic Issue Items Lists are divided into the following sections:

a. Section II. Components of End Item. This listing is for informational purposes only, and is not authority to requisition replacements. These items are part of the end item, but are removed and separately packaged for transportation or shipment. As part of the end item, these items must be with the end item whenever it is issued or transferred between property accounts. Illustrations are furnished to assist you in identifying the items.

b. Section III. Basic Issue Items. These are the minimum essential items required to place the Electric Pensky-Martens Tester in operation, to operate it, and to perform emergency repairs. Although shipped separately packaged, BII must be with the shelter during operation and whenever it is transferred between property accounts. The illustrations will assist you with hard-to-identify items. This manual is your authority to request/requisition replacement BII, based on TOE/MTOE authorization of the end item.

C-3. Explanation of Columns.

The following provides an explanation of columns found in the tabular listings:

a. Column (1) - Illustration Number (Illus Number). This column indicates the number of the illustration in which the item is shown.

b. Column (2) - National Stock Number. Indicates the National stock number assigned to the item and will be used for requisitioning purposes.

c. Column (3) - Description. Indicates the Federal item name and, if required, a minimum description to identify and locate the item. The last line for each item indicates the CAGEC (in parentheses) followed by the part number.

d. Column (4) - Unit of Measure (U/M). Indicates the measure used in performing the actual operational/maintenance function. This measure is expressed by a two-character alphabetical abbreviation (e.g., ea, in, pr).

e. Column (5) - Quantity required (QTY RQR). Indicates the quantity of the item authorized to be used with/on the equipment.

SECTION II. COMPONENTS OF END ITEM				
(1)	(2)	(3)	(4)	(5)
ILLUS	NATIONAL STOCK NUMBER	DESCRIPTION USABLE CAGEC AND PART NUMBER ON CODE	U/M	QTY
		REGULATOR (05083) 0023-1492	EA	2

SECTION III. BASIC ISSUE ITEMS
NOT APPLICABLE

APPENDIX D
ADDITIONAL AUTHORIZATION LIST

NOT APPLICABLE

APPENDIX E

EXPENDABLE/DURABLE SUPPLIES AND MATERIALS LIST

Section I. INTRODUCTION

E-1 . **Scope.** This listing is for informational purposes only and is not authority to requisition the listed items. These items are authorized to you by CTA 50-970, Expendable/Durable Items (except medical, class V, repair parts, and heraldic items).

E-2. Explanation of Columns.

a. Column (1) - Item Number. This number is assigned to the entry in the listing and is referenced in the narrative instructions to identify the material (e.g., Use cleaning compound, item 5, appendix C).

b. Column (2) - Level. This column identifies the lowest level of maintenance that requires the listed item.

- C - Operator/Crew
- O - Unit Maintenance
- F - Direct Support Maintenance
- H - General Support Maintenance

c. Column (3) - National Stock Number. This is the National stock number assigned to the item; use it to request or requisition the item.

d. Column (4) - Description. Indicates the Federal item name, and, if required, a description to identify the item. The last line for each item indicates the Commercial and Government Entity Code (CAGEC) in parentheses followed by the part number.

e. Column (5) - Unit of Measure (U/M). Indicates the measure used in performing the actual maintenance function. This measure is expressed by a two-character alphabetical abbreviation (e.g., EA,IN, PR). if the unit of measure differs from the unit of issue, requisition the lowest unit of issue that will satisfy your requirements.

Section II. EXPENDABLE/DURABLE SUPPLIES AND MATERIALS LIST

(1) Item Number	(2) Level	(3) National Stock Number	(4) Description	(5) U/M
	C	6830-00-269-4299	PROPANE: CYLINDER DISPOSABLE, ODORIZED (SMALL) 1 LB. CYL (80244) BB-6-40, TYPE III	EA

By Order of the Secretary of the Army:

CARL E. VUONO
General, United States Army
Chief of Staff

Official:

THOMAS F. SIKORA
Brigadier General, United States Army
The Adjutant General

DISTRIBUTION:

To be distributed in accordance with DA Form 12-21A, Operator, Unit and Direct Support Maintenance requirements for Laboratory, Air Mobile, Aviation Fuel and Laboratory, Petroleum, MTD

RECOMMENDED CHANGES TO EQUIPMENT TECHNICAL PUBLICATIONS



THEN... JOT DOWN THE DOPE ABOUT IT ON THIS FORM, CAREFULLY TEAR IT OUT, FOLD IT AND DROP IT IN THE MAIL!

SOMETHING WRONG WITH THIS PUBLICATION?

FROM: (PRINT YOUR UNIT'S COMPLETE ADDRESS)

PFC JOHN DOE
COA, 3d ENGINEER BN
FT. LEONARDWOOD, MA 63108

DATE SENT

PUBLICATION NUMBER

TM 10-6630-231-13&P

PUBLICATION DATE

28 Sep 1990

PUBLICATION TITLE Koehler Electric
Pensky-Martens Tester

BE EXACT... PIN-POINT WHERE IT IS

PAGE NO.	PARA-GRAPH	FIGURE NO.	TABLE NO.
6	2-1 a		
B1		4-3	
125	line	20	

IN THIS SPACE TELL WHAT IS WRONG AND WHAT SHOULD BE DONE ABOUT IT:

In line 6 of paragraph 2-1a the manual states the engine has 6 Cylinders. The engine on my set only has 4 Cylinders. Change the manual to show 4 Cylinders.

Callout 16 on figure 4-3 is pointing at a bolt. In key to figure 4-3, item 16 is called a shim - Please correct one or the other.

I ordered a gasket, item 19 on figure B-16 by NSN 2910-00-762-3001. I got a gasket but it doesn't fit. Supply says I got what I ordered, so the NSN is wrong. Please give me a good NSN

PRINTED NAME, GRADE OR TITLE, AND TELEPHONE NUMBER

JOHN DOE, PFC (268) 317-7111

SIGN HERE

JOHN DOE

DA FORM 2028-2
1 JUL 79

PREVIOUS EDITIONS ARE OBSOLETE.

DRSTS-M Overprint 1, 1 Nov 80

P.S.--IF YOUR OUTFIT WANTS TO KNOW ABOUT YOUR RECOMMENDATION MAKE A CARBON COPY OF THIS AND GIVE IT TO YOUR HEADQUARTERS.

TEAR ALONG PERFORATED LINE

FILL IN YOUR
UNIT'S ADDRESS



FOLD BACK

DEPARTMENT OF THE ARMY

OFFICIAL BUSINESS

COMMANDER
U.S. ARMY TROOP SUPPORT COMMAND
ATTN: AMSTR-MCTS
4300 GOODFELLOW BOULEVARD
ST. LOUIS, MO 63120-1798

TEAR ALONG PERFORATED LINE

RECOMMENDED CHANGES TO EQUIPMENT TECHNICAL PUBLICATIONS



THEN... JOT DOWN THE DOPE ABOUT IT ON THIS FORM. CAREFULLY TEAR IT OUT. FOLD IT AND DROP IT IN THE MAIL!

SOMETHING WRONG WITH THIS PUBLICATION?

FROM: (PRINT YOUR UNIT'S COMPLETE ADDRESS)

DATE SENT

PUBLICATION NUMBER

TM 10-6630-231-13&P

PUBLICATION DATE

28 Sep 1990

PUBLICATION TITLE Koehler Electric Pensky-Martens Tester

BE EXACT... PIN-POINT WHERE IT IS

PAGE NO	PARA-GRAPH	FIGURE NO	TABLE NO

IN THIS SPACE TELL WHAT IS WRONG AND WHAT SHOULD BE DONE ABOUT IT:

TEAR ALONG PERFORATED LINE

PRINTED NAME, GRADE OR TITLE, AND TELEPHONE NUMBER

SIGN HERE.

DA FORM 2028-2
1 JUL 79

PREVIOUS EDITIONS ARE OBSOLETE.
DRSTS-M Overprint 2, 1 Nov 80

P.S.--IF YOUR OUTFIT WANTS TO KNOW ABOUT YOUR RECOMMENDATION MAKE A CARBON COPY OF THIS AND GIVE IT TO YOUR HEADQUARTERS.

FILL IN YOUR
UNIT'S ADDRESS



FOLD BACK

DEPARTMENT OF THE ARMY

OFFICIAL BUSINESS

COMMANDER
U.S. ARMY TROOP SUPPORT COMMAND
ATTN: AMSTR-MCTS
4300 GOODFELLOW BOULEVARD
ST. LOUIS, MO 63120-1798

TEAR ALONG PERFORATED LINE

FILL IN YOUR
UNIT'S ADDRESS



FOLD BACK

DEPARTMENT OF THE ARMY

OFFICIAL BUSINESS

COMMANDER
U.S. ARMY TROOP SUPPORT COMMAND
ATTN: AMSTR-MCTS
4300 GOODFELLOW BOULEVARD
ST. LOUIS, MO 63120-1798

TEAR ALONG PERFORATED LINE

The Metric System and Equivalents

Linear Measure

1 centimeter = 10 millimeters = .39 inch
 1 decimeter = 10 centimeters = 3.94 inches
 1 meter = 10 decimeters = 39.37 inches
 1 dekameter = 10 meters = 32.8 feet
 1 hectometer = 10 dekameters = 328.08 feet
 1 kilometer = 10 hectometers = 3,280.8 feet

Weights

1 centigram = 10 milligrams = .15 grain
 1 decigram = 10 centigrams = 1.54 grains
 1 gram = 10 decigrams = .035 ounce
 1 dekagram = 10 grams = .35 ounce
 1 hectogram = 10 dekagrams = 3.52 ounces
 1 kilogram = 10 hectograms = 2.2 pounds
 1 quintal = 100 kilograms = 220.46 pounds
 1 metric ton = 10 quintals = 1.1 short tons

Liquid Measure

1 centiliter = 10 milliliters = .34 fl. ounce
 1 deciliter = 10 centiliters = 3.38 fl. ounces
 1 liter = 10 deciliters = 33.81 fl. ounces
 1 dekaliter = 10 liters = 2.64 gallons
 1 hectoliter = 10 dekaliters = 26.42 gallons
 1 kiloliter = 10 hectoliters = 264.18 gallons

Square Measure

1 sq. centimeter = 100 sq. millimeters = .155 sq. inch
 1 sq. decimeter = 100 sq. centimeters = 15.5 sq. inches
 1 sq. meter (centare) = 100 sq. decimeters = 10.76 sq. feet
 1 sq. dekameter (are) = 100 sq. meters = 1,076.4 sq. feet
 1 sq. hectometer (hectare) = 100 sq. dekameters = 2.47 acres
 1 sq. kilometer = 100 sq. hectometers = .386 sq. mile

Cubic Measure

1 cu. centimeter = 1000 cu. millimeters = .06 cu. inch
 1 cu. decimeter = 1000 cu. centimeters = 61.02 cu. inches
 1 cu. meter = 1000 cu. decimeters = 35.31 cu. feet

Approximate Conversion Factors

To change	To	Multiply by	To change	To	Multiply by
inches	centimeters	2.540	ounce-inches	newton-meters	.007062
feet	meters	.305	centimeters	inches	.394
yards	meters	.914	meters	feet	3.280
miles	kilometers	1.609	meters	yards	1.094
square inches	square centimeters	6.451	kilometers	miles	.621
square feet	square meters	.093	square centimeters	square inches	.155
square yards	square meters	.836	square meters	square feet	10.764
square miles	square kilometers	2.590	square meters	square yards	1.196
acres	square hectometers	.405	square kilometers	square miles	.386
cubic feet	cubic meters	.028	square hectometers	acres	2.471
cubic yards	cubic meters	.765	cubic meters	cubic feet	35.315
fluid ounces	milliliters	29.573	cubic meters	cubic yards	1.308
pints	liters	.473	milliliters	fluid ounces	.034
quarts	liters	.946	liters	pints	2.113
gallons	liters	3.785	liters	quarts	1.057
ounces	grams	28.349	liters	gallons	.264
pounds	kilograms	.454	grams	ounces	.035
short tons	metric tons	.907	kilograms	pounds	2.205
pound-feet	newton-meters	1.356	metric tons	short tons	1.102
pound-inches	newton-meters	.11296			

Temperature (Exact)

°F	Fahrenheit temperature	5/9 (after subtracting 32)	Celsius temperature	°C
----	------------------------	----------------------------	---------------------	----

